

GENOMA

Federndes Druckstück Innensechskant

- Automatenstahl, brüniert
- Kugel gehärtet
- Form N = normaler Federdruck
- Form S = verstärkter Federdruck
- P = Anfangs - Enddruck in N

Produktbild:



Zeichnung:

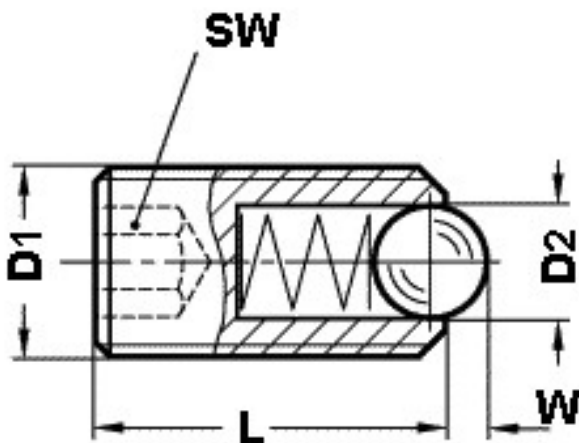

Produktoptionen:

Form	D	D2	L ñ 0,1	W	SW	P [N] Anfang	P [N] Ende	Bestell-Nr.
Form N	M3	1,5	9	0,5	1,5	1,5	3	540-303
Form N	M4	2,5	12	0,8	2	4	10	540-304
Form N	M5	3	14	0,9	2,5	8	14	540-305
Form N	M6	3,5	15	1	3	11	18	540-306
Form N	M8	4,5	18	1,5	4	18	31	540-308
Form N	M10	6	23	2	5	24	45	540-310

Form N	M12	8	26	2,5	6	26	49	540-312
Form N	M16	10	33	3,5	8	41	86	540-316
Form N	M20	12	43	4,5	10	66	111	540-320
Form N	M24	15	48	5,5	12	81	151	540-324
Form S	M3	1,5	9	0,5	1,5	5	7	540-403
Form S	M4	2,5	10	0,8	2	12	22	540-404
Form S	M5	3	14	0,9	2,5	15	22	540-405
Form S	M6	3,5	15	1	3	19	28	540-406
Form S	M8	4,5	18	1,5	4	36	62	540-408
Form S	M10	6	23	2	5	57	104	540-410
Form S	M12	8	26	2,5	6	61	110	540-412
Form S	M16	10	33	3,5	8	68	142	540-416
Form S	M20	12	43	4,5	10	84	166	540-420
Form S	M24	15	48	5,5	12	127	237	540-424